

\*Black frame product can be provided upon request.

## CS6P-250 | 255 | 260P

Canadian Solar's high quality and reliability modules are ensured by our 13 years of module manufacturing experience, well-engineered module design, stringent BOM quality testing, automated manufacturing process and 100% EL testing.

### PRODUCT | KEY FEATURES



Excellent module efficiency up to 16.16%



High performance at low irradiance above 96.5%



Positive power tolerance up to 5w



High PTC rating up to 91.96%



Anti-glare module surface available



IP67 junction box long-term weather endurance



Heavy snow load up to 5400Pa wind load up to 2400Pa



Salt mist, ammonia and blown sand resistance, for seaside, farm and desert environment

### PRODUCT | WARRANTY & INSURANCE

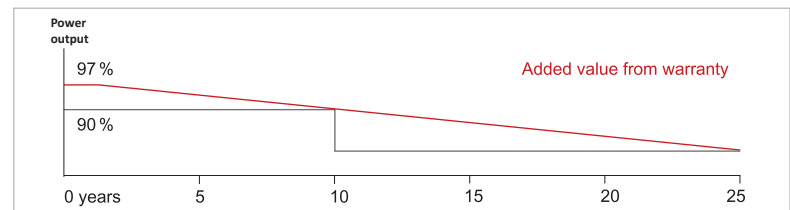

25 Year Linear power output warranty

10 Year Product warranty on materials and workmanship



Canadian Solar provides 100% non-cancellable, immediate warranty insurance

### PRODUCT & MANAGEMENT SYSTEM | CERTIFICATES\*

IEC 61215 / IEC 61730: VDE/CE/MCS/JET/SII/CEC AU / INMETRO/CQC

UL 1703 / IEC 61215 performance: CEC listed ( US ) / FSEC (US Florida)

UL 1703: CSA | IEC 61701 ED2: VDE | IEC 62716: TUV | IEC60068-2-68: SGS

PV CYCLE (EU) | UNI9177 Reaction to Fire: Class 1

ISO9001: 2008 | Quality management system

ISOTS16949:2009 | The automotive industry quality management system

ISO14001:2004 | Standards for environmental management system

OHSAS18001:2007 | International standards for occupational health and safety

\*Please contact your sales representative for the entire list of certificates applicable to your products



### CANADIAN SOLAR INC.

Founded in 2001 in Canada, Canadian Solar Inc., (NASDAQ: CSIQ) is the world's TOP 3 solar power company. As a leading manufacturer of solar modules and PV project developer with about 7 GW of premium quality modules deployed around the world in the past 13 years, Canadian Solar is one of the most bankable solar companies in Europe, USA, Japan and China. Canadian Solar operates in six continents with customers in over 90 countries and regions. Canadian Solar is committed to providing high quality solar products, solar system solutions and services to customers around the world.



## ELECTRICAL DATA | STC

Electrical Data	CS6P-250P	CS6P-255P	CS6P-260P
Nominal Maximum Power (Pmax)	250 W	255 W	260W
Optimum Operating Voltage (Vmp)	30.1 V	30.2 V	30.4V
Optimum Operating Current (Imp)	8.30 A	8.43 A	8.56A
Open Circuit Voltage (Voc)	37.2 V	37.4 V	37.5V
Short Circuit Current (Isc)	8.87 A	9.00 A	9.12A
Module Efficiency	15.54 %	15.85 %	16.16%
Operating Temperature	-40 °C~+85 °C		
Maximum System Voltage	1000V (IEC) / 1000V (UL) / 600V (UL)		
Maximum Series Fuse Rating	15 A		
Application Classification	Class A		
Power Tolerance	0 ~ +5 W		

Under Standard Test Conditions (STC) of irradiance of 1000W/m<sup>2</sup>, spectrum AM 1.5 and cell temperature of 25°C.

## ELECTRICAL DATA | NOCT

Electrical Data	CS6P-250P	CS6P-255P	CS6P-260P
Nominal Maximum Power (Pmax)	181 W	185 W	189W
Optimum Operating Voltage (Vmp)	27.5 V	27.5 V	27.7V
Optimum Operating Current (Imp)	6.60 A	6.71 A	6.80A
Open Circuit Voltage (Voc)	34.2 V	34.4 V	34.5V
Short Circuit Current (Isc)	7.19 A	7.29 A	7.39A

Under Nominal Operating Cell Temperature(NOCT), irradiance of 800 W/m<sup>2</sup>, spectrum AM 1.5, ambient temperature 20°C, wind speed 1 m/s.

## MODULE | MECHANICAL DATA

Specification	Data
Cell Type	Poly-crystalline, 6inch
Cell Arrangement	60 (6 x 10)
Dimensions	1638 x 982 x 40mm (64.5 x 38.7 x 1.57in)
Weight	18.5kg (40.8 lbs)
Front Cover	3.2mm tempered glass
Frame Material	Anodized aluminium alloy
Junction BOX	IP67, 3 diodes
Cable	4mm <sup>2</sup> (IEC)/4mm <sup>2</sup> &12AWG 1000V(UL1000V)/12AWG(UL600V), 1000mm (650mm is optional)
Connectors	MC4 or MC4 comparable
Standard Packaging	24pcs, 504kg (quantity and weight per pallet)
Module Pieces Per Container	672pcs (40'HQ)

## TEMPERATURE CHARACTERISTICS

Specification	Data
Temperature Coefficient (Pmax)	-0.43 %/°C
Temperature Coefficient (Voc)	-0.34 %/°C
Temperature Coefficient (Isc)	0.065 %/°C
Nominal Operating Cell Temperature	45±2 °C

## PERFORMANCE AT LOW IRRADIANCE

Industry leading performance at low irradiation, +96.5% module efficiency from an irradiance of 1000W/m<sup>2</sup> to 200W/m<sup>2</sup> (AM 1.5, 25 °C)

## MODULE | ENGINEERING DRAWING (unit: mm)

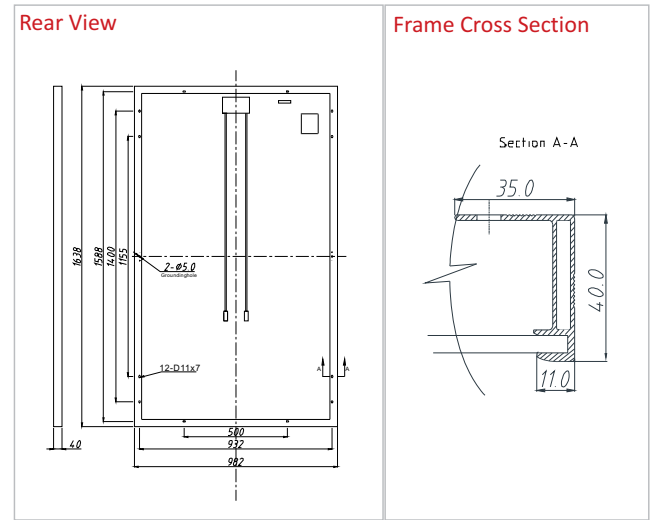

## CS6P-255P | I-V CURVES

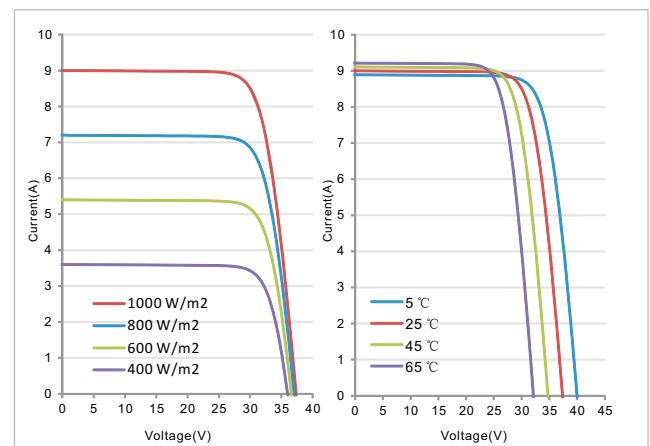

## Partner Section

As there are different certification requirements in different markets, please contact your sales representative for the specific certificates applicable to your products. The specification and key features described in this Datasheet may deviate slightly and are not guaranteed. Due to on-going innovation, research and product enhancement, Canadian Solar Inc. reserves the right to make any adjustment to the information described herein at any time without notice. Please always obtain the most recent version of the datasheet which shall be duly incorporated into the binding contract made by the parties governing all transactions related to the purchase and sale of the products described herein.